

Elettropompe sommergibili con girante bicanale centrifugo

Submersible electro pumps with centrifugal twin channel impeller

Potenze / Power:	12÷42 kW
Mandate / Delivery:	DN80-100



Impieghi

La serie ATH 2 poli trova impiego nel pompaggio e nella movimentazione di grandi quantità di liquidi chiari e parzialmente fognari ad altissime prevalenze.

Applicazioni: depuratori, canalizzazioni industriali, fognature, strutture aeroportuali, ospedaliere e civili, nell'agricoltura e irrigazione.

Caratteristiche

Tutti i componenti principali sono realizzati in Ghisa GG25. Due tenute meccaniche separate (lato motore a bagno olio, lato girante a contatto con il liquido) e componentistica di prima qualità, ne garantiscono il perfetto funzionamento.

Motori

- Motori asincroni 2 poli con rotore a gabbia di scoiattolo
- Protezione termica T1 e T2 incorporato nel motore da collegare ad un apposito quadro di comando
- Isolamento statore classe F (155°C)
- Grado protezione IP 68

Raffreddamento

Raffreddamento effettuato dal liquido nel quale la pompa è immersa.

Limiti di impiego

- Temperatura massima del liquido: 40°C con unità completamente sommersa
- Disponibili versioni speciali (escluso ATEX) fino alla temperatura liquido di 60°C con unità completamente sommersa, non a servizio continuo (S1)
- Massima profondità di immersione: 20 mt
- Valori pH ammessi: 6-10
- Caratteristiche idrauliche valide per liquidi di densità <1,1 kg/dm³
- Tensioni ammesse: 230/400V o 400/690V ±5% a seconda del modello
- Frequenza ammessa: 50Hz ± 2%

Applications

The ATH 2 poles Series is used to move large volumes of clear water or light sewage with high performance.

Applications: water treatment plants, industrial plants, airports, hospitals and civil applications and agricultural irrigation.

Characteristic

All main components are made of grey cast iron GG25. Two individual mechanical seals (motor side in the oil chamber, impeller side in contact with the liquid) and high quality parts, ensure the perfect functioning and reliability of the product.

Motor range

- Squirrel cage motor at 2 poles
- Thermal protection T1 and T2 embedded in the motor winding (to be wired to the three pole contactor in the control panel)
- Class F insulation (155°C)
- IP 68 protection

Motor cooling

The cooling of the motor is ensured by the liquid where the pump is submerged.

Limits of use

- Max. permissible liquid temperature: 40°C with pump fully submerged
- On request, special version (excluded ATEX) to withstand liquid temperature up to 60°C with pump fully submerged, no S1 service
- Maximum depth of immersion: 20 mt.
- Permissible pH value: 6-10
- Hydraulic features suitable for liquids with density <1,1 kg/dm³
- Allowed voltage: 230/400V or 400/690V ±5% depending on the pump
- Allowed frequency: 50Hz ± 2%

Designazione / Designation

ATH-EX 100 - 2 / 250

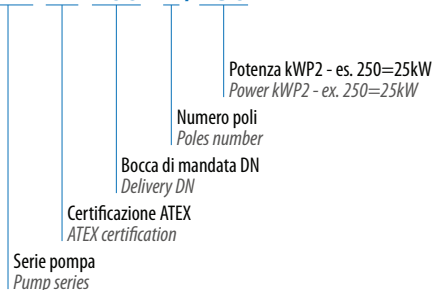

Campo di Prestazione / Performance Overview

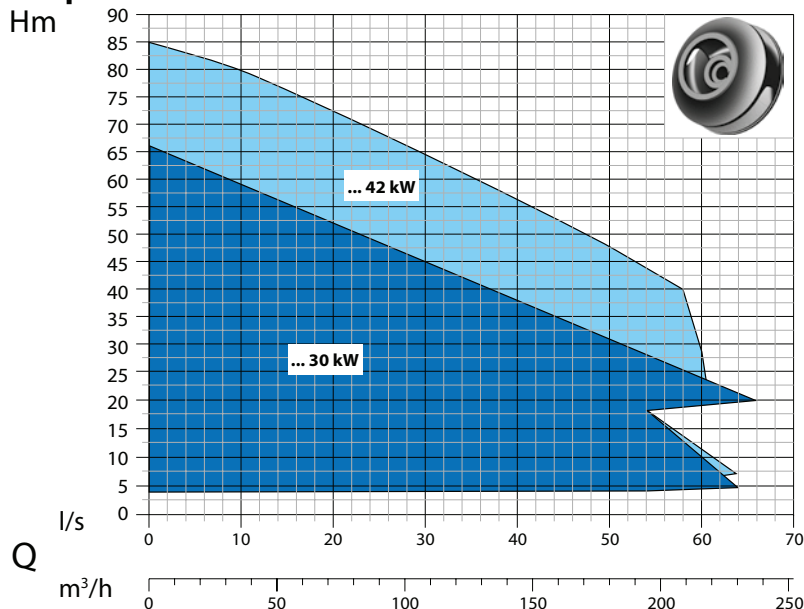

Identificazione Curve

Curves Identification

- DN80
- DN100

Normative

Norms

Curve secondo ISO 9906 livello 2
According to ISO 9906 level 2

Distinta dei componenti e materiali

List of components and materials

ATH
2 POLI
POLES

Anello catena - Chain ring

Acciaio Inox AISI 416 - Stainless steel AISI 416

Cassa Motore - Motor casing

Ghisa GG25 - Cast Iron GG25

Porta cuscinetto superiore - Upper bearing support

Ghisa GG25 - Cast Iron GG25

Cuscinetto superiore - Upper bearing

Albero motore - Motor shaft

Acciaio Inox AISI 420 - Stainless steel AISI 420

Motore elettrico - Electric motor

Rotore - Rotor

Cuscinetto Inferiore - Lower bearing

Porta motore - Motor holder

Ghisa GG25 - Cast iron GG25

Tenuta meccanica - Mechanical seal

Carburo di silicio - Silicon/Carbide (SiC/SiC/Viton)

Tenuta meccanica - Mechanical seal

Carburo di silicio - Silicon/Carbide (SiC/SiC/Viton)

Corpo pompa - Body pump

Ghisa GG25 - Cast Iron GG25

Girante - Impeller

Ghisa GG25 - Cast iron GG25

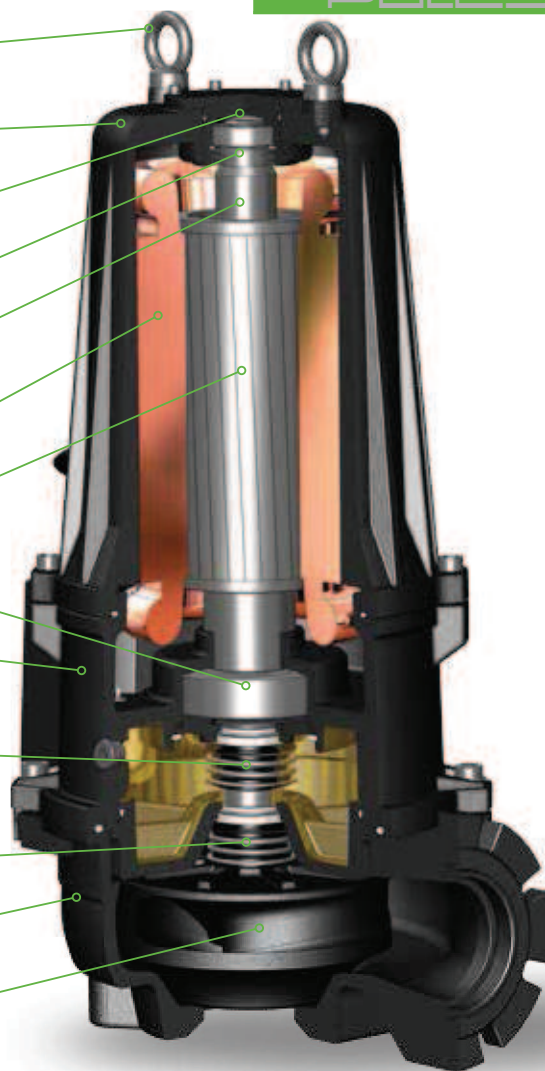

Tecnologie e Soluzioni

Technology and Features



Giranti

La serie monta giranti bicanali centrifughi che sono in grado di trasferire al liquido pompato elevate pressioni e prevalenze. Passaggi solidi fino a 45mm.

Impellers

The ATH centrifugal double-channel impeller are suitable for pumping large flow at very high pressure with free passage of solids up to 45 mm.



Pompe antideflagranti / Explosion proof pumps

CE 0477  II 2 G EX db k IIB T4 X 0°C ≤ Ta ≤ 40°C
EX db IIB T4 X 0°C ≤ Ta ≤ 40°C

I presenti certificati garantiscono la sicurezza contro le esplosioni, in assoluta conformità con le stringenti direttive europee ed internazionali ATEX/IECEx.

These certificates grant for the safe use of the product in hazardous area in line with the stringent European and International standards ATEX/IECEx.



Sensore d'umidità

Sensore conforme alle norme sulla sicurezza integrata contro le esplosioni EN 60079-0, EN 60079-1 tramite barriera di protezione. Di serie su tutta la gamma (non applicabile con IECEx).



Seal leak detector

The seal leak detector is certified according to the norm through safety barrier EN 60079-0, EN 60079-1 and fitted. Standard on all series (not applicable with IECEx).

Cuscinetti

La serie monta il cuscinetto superiore a rulli cilindrici, atto ad assorbire e resistere ad eventuali sollecitazioni trasmesse dall'albero motore.



Bearings

The series is fitted with a cylindrical roller bearing (upper bearing) to absorb the thrust and vibration generated by the pump shaft.

Mandata Orizzontale DN80 PN16 - RPM 2850 1/min 2 poli

Horizontal Outlet DN80 PN16 - RPM 2850 1/min 2 poles

Immagine a solo scopo illustrativo
Picture for illustration purposes only



Curva di Prestazione Performance Curve

L = rendimento massimo pompa
maximum pump efficiency

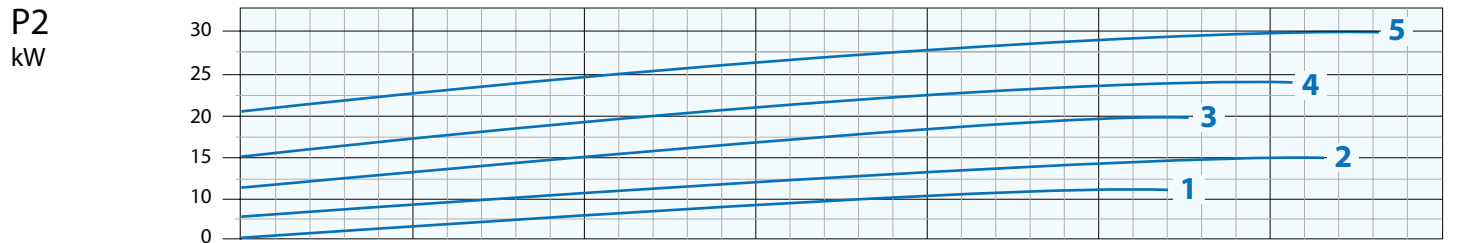
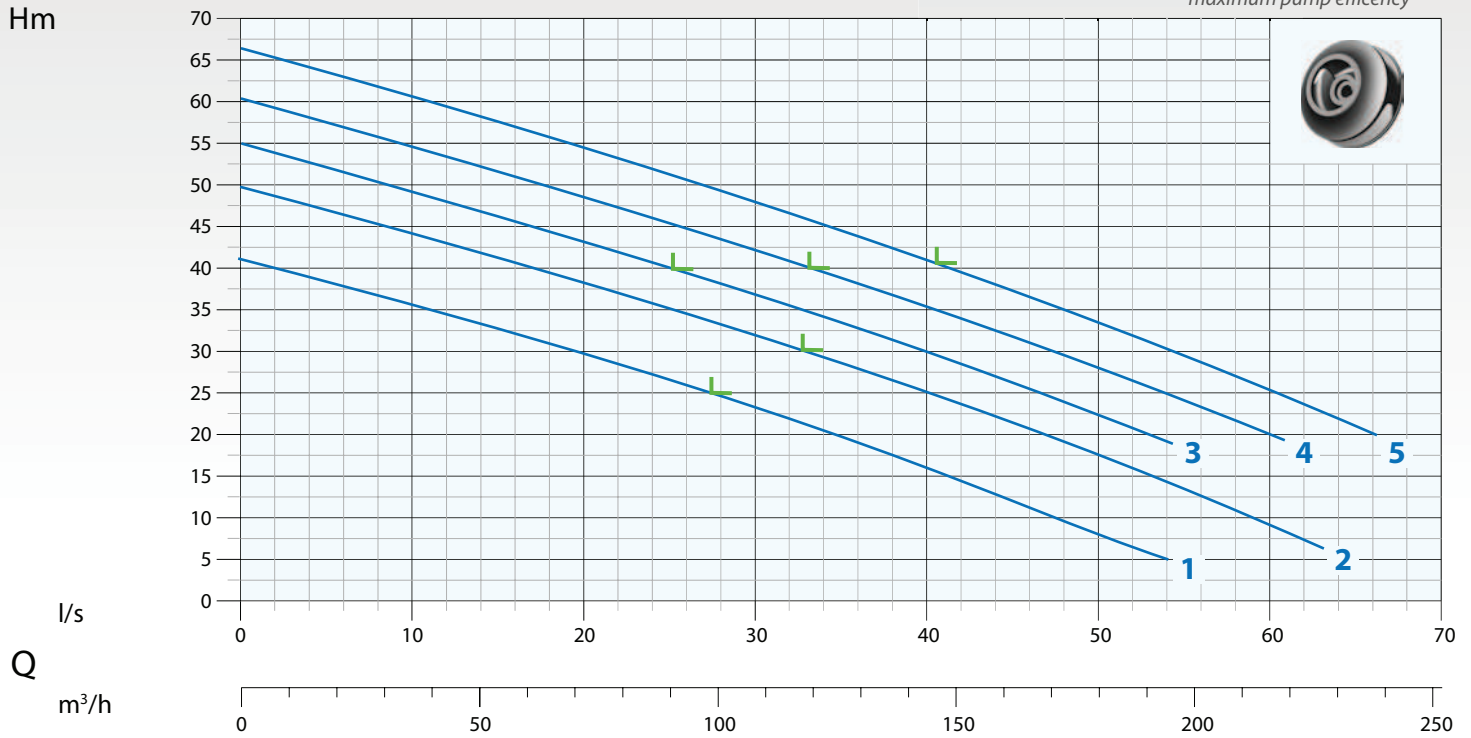

N°	Tipo Type	l/s	6	10	20	30	40	44	50	54	60	62
			l/m	360	600	1200	1800	2400	2640	3000	3240	3600
		m³/h	21,6	36	72	108	144	158,4	180	194,4	216	223,2
1	ATH 80-2/120	mt	37,5	35	30	22,5	16,5	12,5	7,5	5		
2	ATH 80-2/150		47	44	38	32,5	25	22,5	17,5	14	8	7,5
3	ATH 80-2/200		52	49	43	37	30	27,5	22,5	19		
4	ATH 80-2/250		57	55	48	42,5	35	32,5	28	25	20	
5	ATH 80-2/300		62,5	60	55	47,5	41,5	37,5	33	30	25	23

N°	Tipo Type	EX	Mandata Delivery	Passaggio Free Passage	kW		HP	R.P.M. 1/min	A 3 Phase - 400V	Hz
					P1	P2				
1	ATH 80-2/120	•	DN80 PN16	33 mm	13,8	12	16	2850	23	50
2	ATH 80-2/150	•			18,5	15	20		29,4	
3	ATH 80-2/200	•		23,8	20	27	41,2			
4	ATH 80-2/250	•		29,8	25	34	48,4			
5	ATH 80-2/300	•		33,9	30	41	54,4			

• Pompa antideflagrante disponibile con certificazioni: II 2 G EX db k IIB T4 X 0°C ≤ Ta ≤ 40°C
Available explosion proof pump with certifications: EX db IIB T4 X 0°C ≤ Ta ≤ 40°C

∇ Sommergenza minima
Minimum submersion

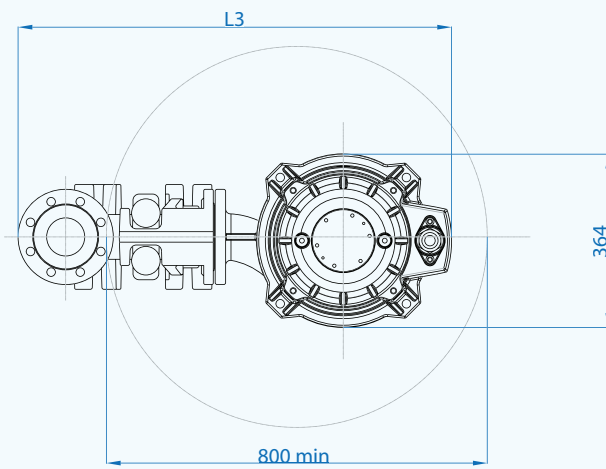
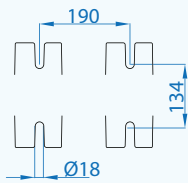
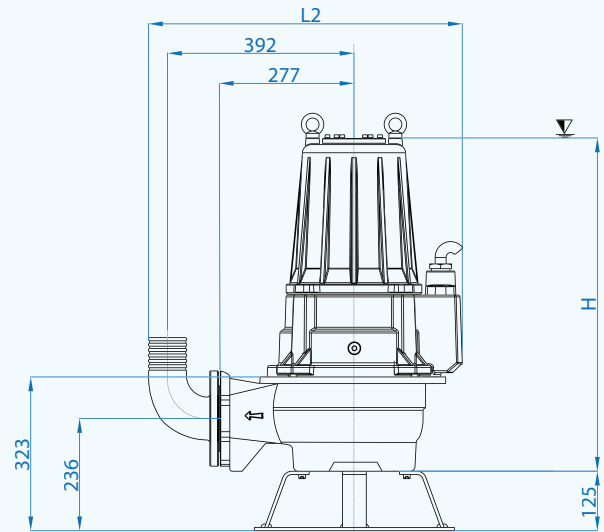
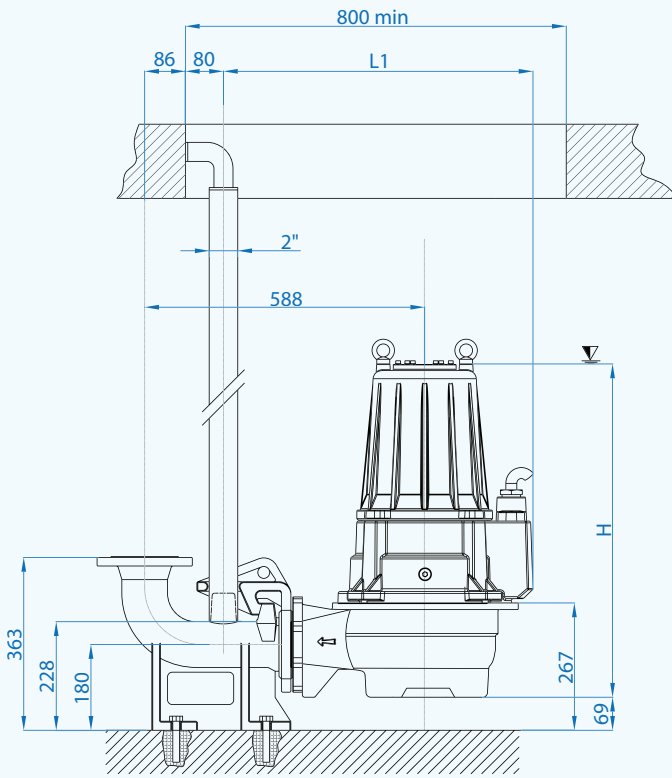

DN80 PN16
ex UNI 2278

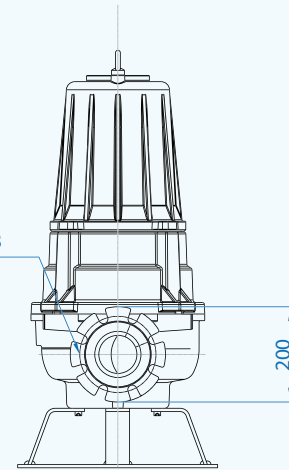

	H	L1	L2	L3
ATH 80-2/120-150	700	650	655	911
ATH 80-2/200-250	741	678	683	934
ATH 80-2/300	808	678	683	934

Cavi / Cables

Pompe Pumps	Versione Version	Fasi Phases	Cavo Cable	Sezione cavo mm ² Cable cross section mm ²	mt
80-2/120-150	Standard	3 ~ 400V	H07RN8F	10x2,5 Ø23*	10
	ATEX	Y-Δ	NSSHÖU-J	7x2,5+3x0,50 Ø20*	10
80-2/200-250	Standard	3 ~ 400V	H07RN8F	7x4+3x1 Ø20,5*	10
	ATEX	Y-Δ	NSSHÖU-J	7x6+3x1 Ø24*	10
80-2/300	Standard	3 ~ 400V	NSSHÖU-J	7x6+3x1 Ø24*	10
	ATEX	Y-Δ	NSSHÖU-J	7x6+3x1 Ø24*	10

* Terminali liberi - Free terminal

Dimensioni imballo / Packaging dimension

Tipo - Type	X mm	Y mm	Z mm	Kg
ATH 80-2/120				190
ATH 80-2/150				200
ATH 80-2/200	510	860	420	247
ATH 80-2/250				250
ATH 80-2/300				393

Accessori - Optional



Piede di accoppiamento
Tipo: DUTY 80 e B5
Automatic coupling foot
Type: DUTY 80 and B5



Curva flangiata con portagomma N2
Base di sostegno P7
Flanged hose connection N2
Foot support P7

Mandata Orizzontale DN100 PN16 - RPM 2850 1/min 2 poli

Horizontal Outlet DN100 PN16 - RPM 2850 1/min 2 poles

Immagine a solo scopo illustrativo
Picture for illustration purposes only



Curva di Prestazione Performance Curve

L = rendimento massimo pompa
maximum pump efficiency

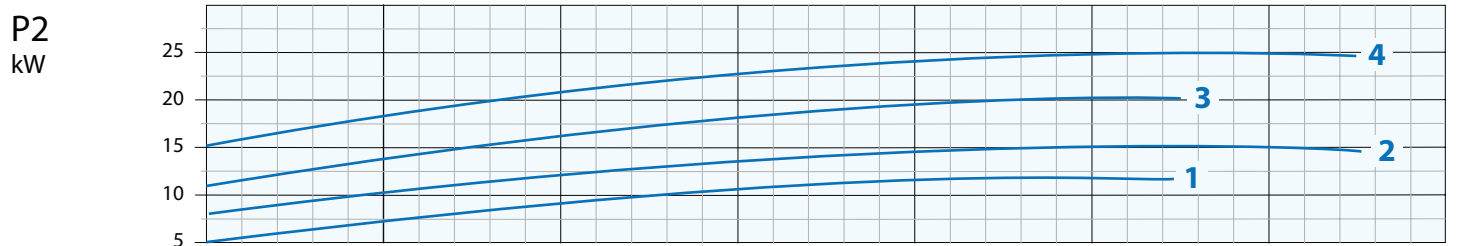
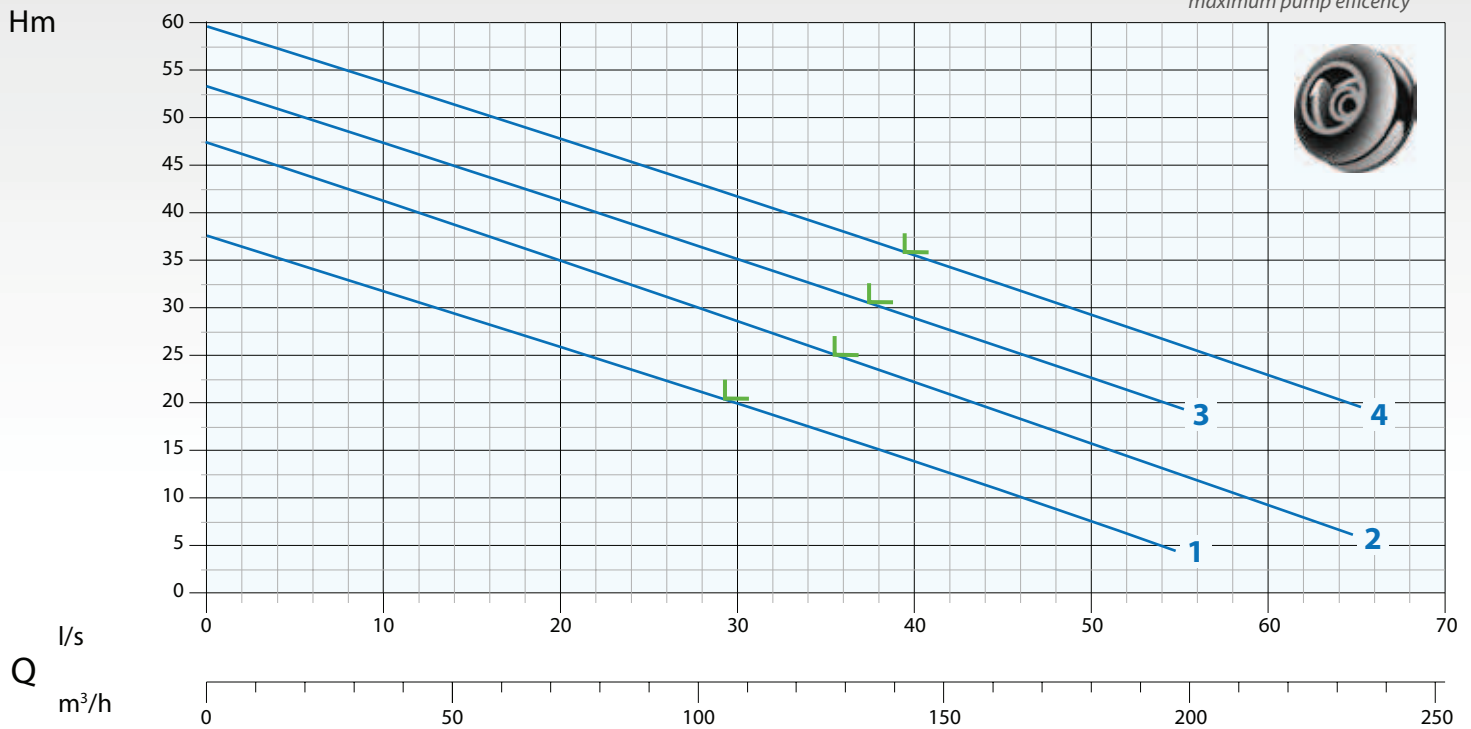

N°	Tipo Type	l/s	6	10	20	30	40	44	50	54	60	62
			l/m	360	600	1200	1800	2400	2640	3000	3240	3600
		m³/h	21,6	36	72	108	144	158,4	180	194,4	216	223,2
1	ATH 100-2/120	mt	34	32	26	20	14	11	7,5	5		
2	ATH 100-2/150		44	41,5	35	28	22,5	20	16,5	13	9	7,5
3	ATH 100-2/200		50	47,5	41,5	35	28,5	27,5	23,5	20		
4	ATH 100-2/250		57	53,5	47,5	42	35	32,5	29	27	22,5	21,5

N°	Tipo Type	EX	Mandata Delivery	Passaggio Free Passage	kW		HP	R.P.M. 1/min	Poli Poles	A	Hz
					P1	P2				3 Phase - 400V	
1	ATH 100-2/120	•	DN100 PN16	33 mm	13,8	12	16	2850	2	22,9	50
2	ATH 100-2/150	•			18,5	15	20	2850		29,6	
3	ATH 100-2/200	•		40 mm	23,8	20	27	2850		42,6	
4	ATH 100-2/250	•			29,8	25	34	2850		49,6	

• Pompa antideflagrante disponibile con certificazioni: II 2 G EX db k IIB T4 X 0°C ≤ Ta ≤ 40°C
Available explosion proof pump with certifications: EX db IIB T4 X 0°C ≤ Ta ≤ 40°C

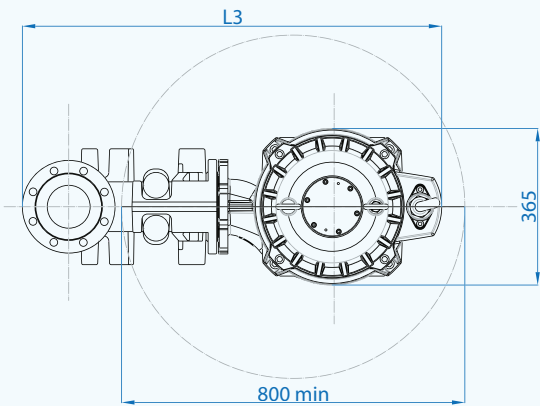
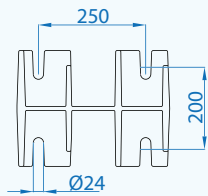
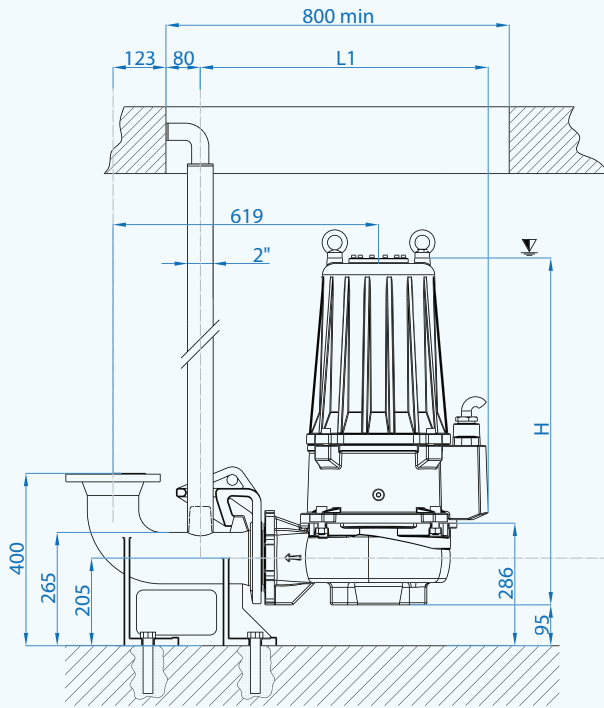

∇ Sommergenza minima
Minimum submersion

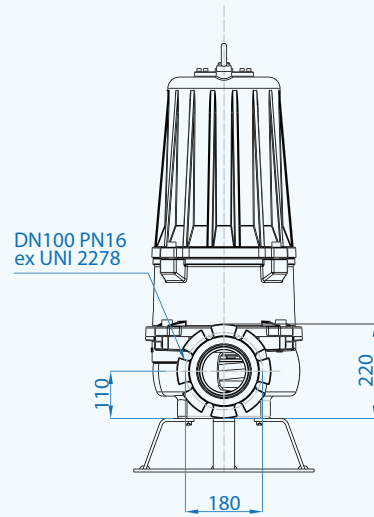
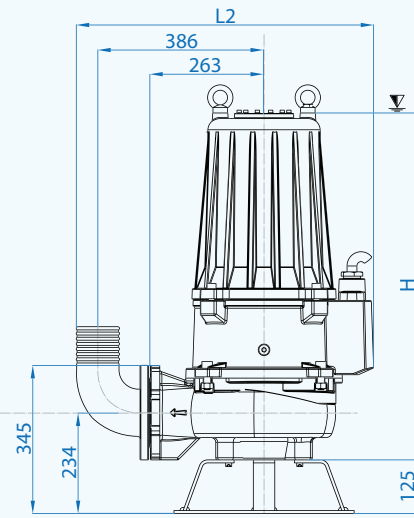

	H	L1	L2	L3
ATH 100-2/120-150	693	734	663	949
ATH 100-2/200-250	734	671	693	977

Cavi / Cables

Pompe Pumps	Versione Version	Fasi Phases	Cavo Cable	Sezione cavo mm ² Cable cross section mm ²	mt
100-2/120-150	Standard	3 ~ 400V	H07RN8F	10x2,5 Ø23*	10
	ATEX	Y-Δ	NSSHÖU-J	7x2,5+3x0,50 Ø20*	10
100-2/200-250	Standard	3 ~ 400V	H07RN8F	7x4+3x1 Ø20,5*	10
	ATEX	Y-Δ	NSSHÖU-J	7x6+3x1 Ø24*	10

* Terminali liberi - Free terminal

Dimensioni imballo / Packaging dimension

Tipo - Type	X mm	Y mm	Z mm	Kg
ATH 100-2/120	510	860	420	190
ATH 100-2/150				200
ATH 100-2/200				247
ATH 100-2/250				250

Accessori - Optional



Piede di accoppiamento
Tipo: DUTY 100 e B6
Automatic coupling foot
Type: DUTY 100 and B6



Curva flangiata con portagomma N3
Base di sostegno P7
Flanged hose connection N3
Foot support P7

Mandata Orizzontale DN100 PN16 - RPM 2900 1/min 2 poli

Horizontal Outlet DN100 PN16 - RPM 2900 1/min 2 poles

Immagine a solo scopo illustrativo
Picture for illustration purposes only



Curva di Prestazione Performance Curve

L = rendimento massimo pompa
maximum pump efficiency

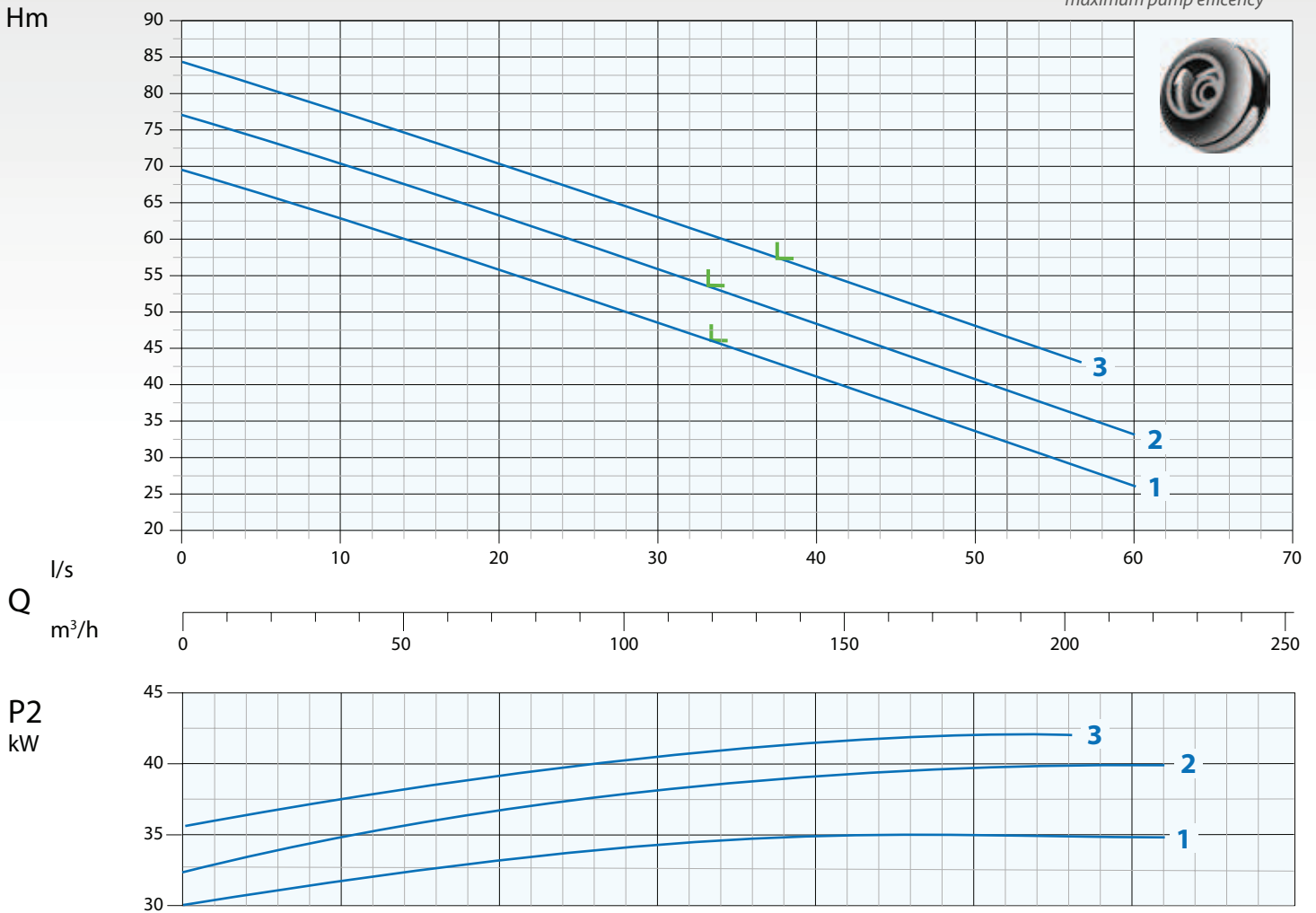

N°	Tipo Type		I/s	6	10	20	30	34	40	44	50	54	60
			l/m	360	600	1200	1800	2040	2400	2640	3000	3240	3600
		m³/h	21,6	36	72	108	122,4	144	158,4	180	194,4	216	
1	ATH 100-2/350		65	62,5	56	48	45	42	37,5	33	30	27	
2	ATH 100-2/400	mt	72,5	70	62,5	56,5	52,5	48	45	41	37,5	33	
3	ATH 100-2/420		80	77,5	70	62,5	60	55	52,5	47,5	45		

N°	Tipo Type	EX	Mandata Delivery	Passaggio Free Passage	kW			R.P.M. 1/min	A	Hz
					P1	P2	HP		3 Phase - 400V	
1	ATH 100-2/350	•			40,5	35	47,5		64,4	
2	ATH 100-2/400	•	DN100 PN16	45 mm	48,3	40	54	2900	76	50
3	ATH 100-2/420	•			51,7	42	57		80,9	

• Pompa antideflagrante disponibile con certificazioni: II 2 G EX db k IIB T4 X 0°C ≤ Ta ≤ 40°C
Available explosion proof pump with certifications: EX db IIB T4 X 0°C ≤ Ta ≤ 40°C

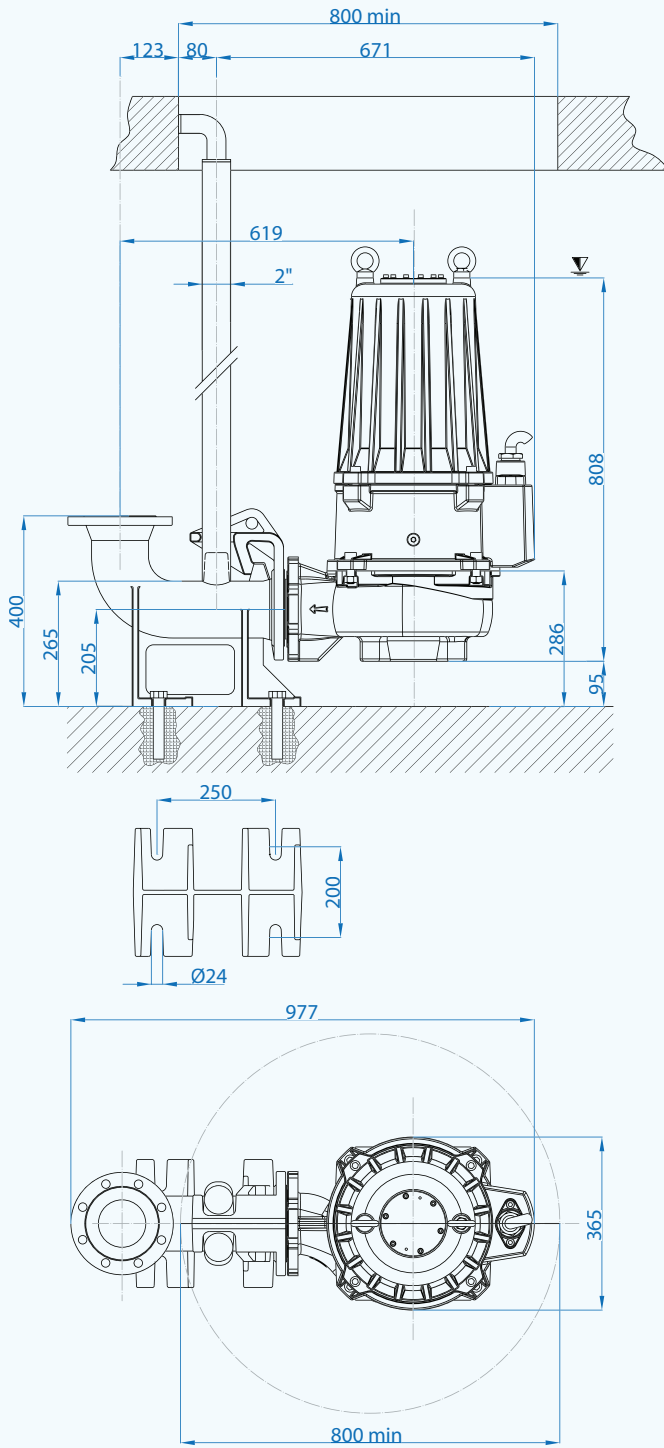

∇ Sommergenza minima
Minimum submersion

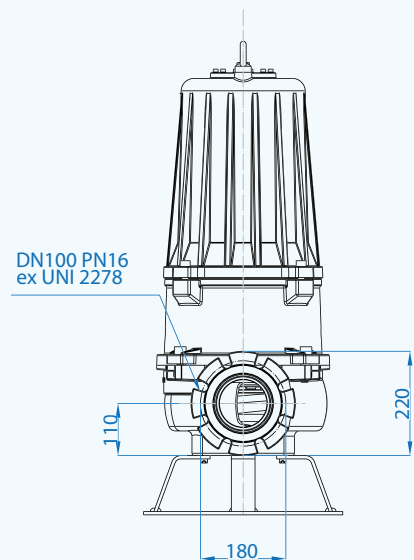
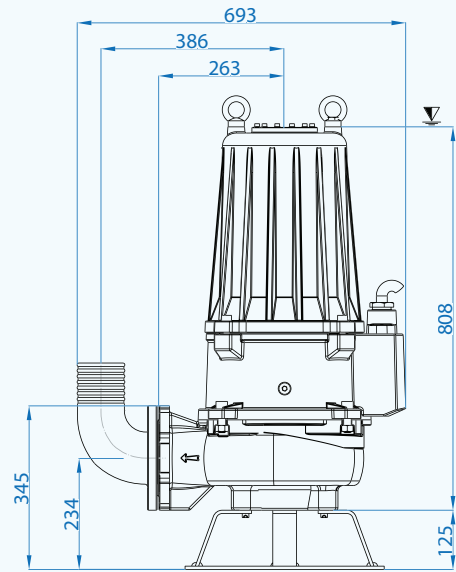

Cavi / Cables

Versione Version	Fasi Phases	Cavo Cable	Sezione cavo mm ² Cable cross section mm ²	mt
Standard	3 ~ 400V	NSSHÖU-J	7x6+3x1 Ø24*	10
ATEX	Y-Δ			10

* Terminali liberi - Free terminal

Dimensioni imballo / Packaging dimension

Tipo - Type	X mm	Y mm	Z mm	Kg
ATH 100-2/350				392
ATH 100-2/400	510	860	420	399
ATH 100-2/420				405

Accessori - Optional



Piede di accoppiamento
Tipo: DUTY 100 e B6
Automatic coupling foot
Type: DUTY 100 and B6



Curva flangiata con portagomma N3
Base di sostegno P7
Flanged hose connection N3
Foot support P7